

DESIGN NOTES

100V Controller Drives High Power LED Strings from Just about Any Input – Design Note 461

by Keith Szolusha

Introduction

Strings of high power solid-state LEDs are replacing traditional lighting technologies in large area and high lumens light sources because of their high quality light output, unmatched durability, relatively low lifetime cost, constant-color dimming and energy efficiency. The list of applications grows daily, including LCD backlights and projection, industrial and architectural lighting, automotive lights, streetlights, billboards and stadium lights.

As the list expands, so does the range of V_{IN} for the LED drivers. LED drivers must be able to handle wide ranging inputs, including transient voltages of automotive batteries, a wide range of other batteries and wall wart voltages. For LED lighting manufacturers, applying a different LED driver for each application means stocking, testing and designing with a number of controllers. It would be better to use just one that can be applied to many solutions.

The LT3756 high voltage LED driver features a unique topological versatility that allows it to be used in boost, buck-boost mode, buck mode, SEPIC, flyback and other topologies. Its high power capability provides potentially hundreds of watts of LED power over a wide input voltage

range. Its 100V floating LED current sense inputs provide accurate LED current sensing. Excellent PWM dimming architecture produces high dimming ratios.

A number of features protect the LEDs and surrounding components. Shutdown and undervoltage lockout, when combined with analog dimming derived from the input, provide the standard ON/OFF feature as well as a reduced LED current should the battery voltage drop to unacceptably low levels. Analog dimming is accurate and can be combined with PWM dimming for a wide range of brightness control. Soft-start prevents spiking inrush currents. The $\overline{OPENLED}$ pin informs of open or missing LEDs and the SYNC (LT3756-1) pin can be used to sync switching to an external clock. The FB voltage loop limits the max V_{OUT} to protect the converter in the case of open LEDs.

The 16-pin IC is available in a tiny QFN (3mm × 3mm) and an MSE package, both thermally enhanced. For lower input voltage requirements, the 40V_{IN}, 75V_{OUT} LT3755 LED controller is a similar option.

LT, LT, LTC and LTM are registered trademarks of Linear Technology Corporation. All other trademarks are the property of their respective owners.

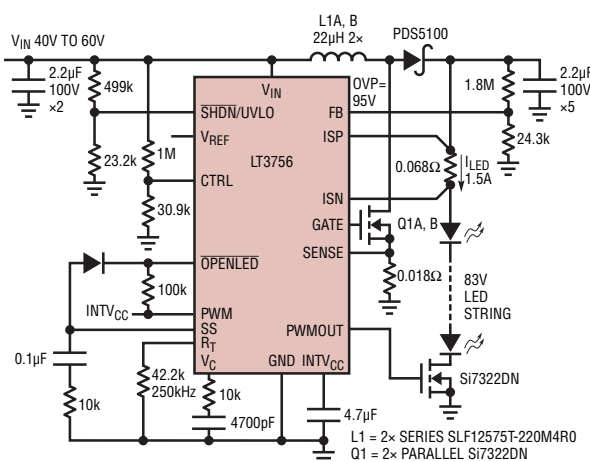

Figure 1. A 125W, 83V at 1.5A, 97% Efficient Boost LED Driver for Stadium Lighting

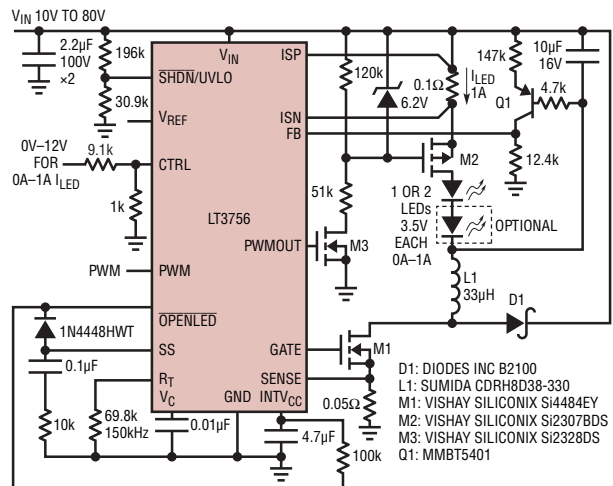

Figure 2. An 80V_{IN} Buck Mode LED Driver With PWM Dimming for Single or Double LEDs

Boost

Lighting systems for stadiums, spotlights and billboards require huge strings of LEDs running at high power. The LT3756 controller drives up to 100V LED strings. The 125W LED driver in Figure 1 has a 40V–60V input.

The high power gate driver switches two 100V MOSFETs at 250kHz. This switching frequency minimizes the size of the discrete components while maintaining high 97% efficiency, producing a less-than-50°C discrete component temperature rise—more manageable than the heat produced by the 125W LEDs.

Even if PWM dimming is not required, the PWMOUT MOSFET is useful for LED disconnect during shutdown. It prevents current from running through the string of LEDs.

If the LED string is removed, the FB constant-voltage loop takes over and regulates the output at 95V. Without overvoltage protection, the LED sense resistor would see zero current and the output cap voltage would go over 100V, exceeding several max ratings. While in OVP OPENLED goes low.

Buck Mode

When V_{IN} is higher than V_{LED} , the LT3756 can serve equally well as a buck mode LED driver. The buck mode LED driver in Figure 2 operates with a wide 10V-to-80V input range to drive one or two LEDs at 1A.

PWM dimming requires a level-shift from the PWMOUT pin to the high-side LED string. The max PWM dimming ratio increases with higher switching frequency, lower PWM dimming frequency, higher V_{IN} and lower LED power. In this case, a 100:1 dimming ratio is possible with a 100Hz dimming frequency and a 48V input. Although higher switching frequency is possible, the duty cycle has its limits. Generous minimum on-time and minimum off-time restrictions require a frequency on the lower end of its range (150kHz) to meet both the harsh high- V_{IN} -to-low- V_{LED} (80V $_{IN}$ to one 3.5V LED) and low- V_{IN} -dropout requirements (10V $_{IN}$ to 7V $_{LED}$).

OVP of the buck mode LED driver has a level shift as well. Without the level-shifted OVP network tied to FB, an open LED string would result in the output capacitor charging up to V_{IN} . Although the buck mode components will survive this scenario, the LEDs may not survive being plugged into a potential equal to V_{IN} .

Buck-Boost Mode

A common LED driver requirement is that the ranges of both the LED string voltage and the input voltage are wide and overlapping. In fact, some designers prefer to use the same LED driver circuit for several different battery sources and several different LED strings. Such a versatile configuration trades some efficiency, component cost, and board space for design simplicity, and time-to-market.

The buck-boost mode driver in Figure 3 uses a single inductor. It accepts inputs from 9V to 36V to drive 10V–50V LED strings at 400mA.

The inductor current is the sum of the input current and the LED string current; the peak inductor current is equal to the peak switching current. Below 9V input, CTRL analog dimming scales back the LED current to keep the inductor current under control. UVLO turns off the LEDs below 6V $_{IN}$. C_{OUT} , DI and MI can see voltages as high as 95V here.

Conclusion

The LT3756 controller is a versatile high power LED driver. It has all the features required for large (and small) strings of high power LEDs. Its high voltage rating, optimized LED driver architecture, high performance PWM dimming, host of protection features and accurate high side current sensing make the LT3756 a single-IC choice for a variety of lighting systems.

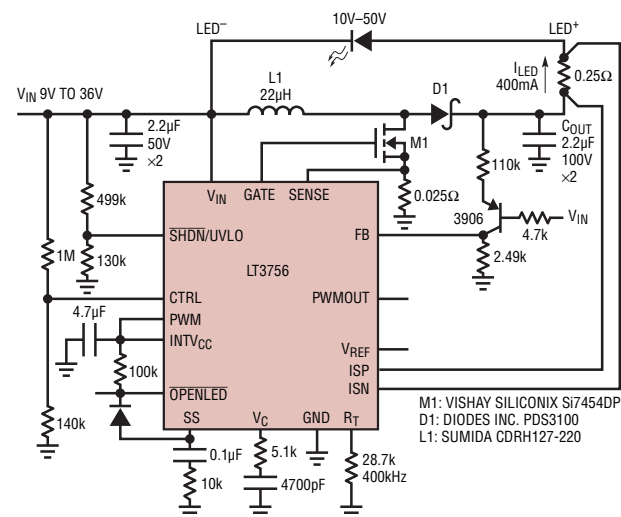

Figure 3. A Buck-Boost Mode LED Driver With Wide-Ranging V_{IN} and V_{LED}

For applications help,
call (408) 432-1900, Ext. 3801

Data Sheet Download

www.linear.com

Linear Technology Corporation
1630 McCarthy Blvd., Milpitas, CA 95035-7417
(408) 432-1900 • FAX: (408) 434-0507 • www.linear.com

dn461 LT/TP 0309 155K • PRINTED IN THE USA

© LINEAR TECHNOLOGY CORPORATION 2009